

TECHNISCHE INFORMATIONEN

Balgen :	2,5 Falten
Federweg :	11 mm
Form :	2,5 Falten
Höhe :	19
Horizontalkraft :	22 N
Kategorie :	Falten
Lippendurchmesser :	25 mm
Rohrinnendurchmesser :	5mm
Serie :	96C
Sortiment :	Sauggreifer
Vertikalkraft :	11 N

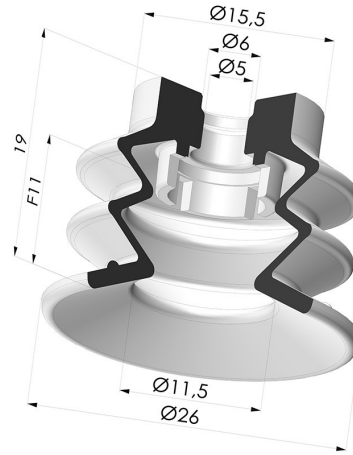





Varianten:



Variantenreferenz:
96C 25PU A

- Farbe: Grün / Gelb
- Materiale: Polyurethan
- Shore-Härte: SH60 / SH30

Ähnliche Produkte:

 Abtrennbarer Halter IG M5 Produktreferenz: 9PM5-2	 Abtrennbarer Halter IG M5 - mit Filter Produktreferenz: 9PM5-2-F	 Abtrennbarer Halter IG M5 - mit Düse Produktreferenz: 9PM5-2-GIC	 Abtrennbarer Halter AG 1/8G - mit Filter Produktreferenz: 9PM18-4-F	 Abtrennbarer Halter IG 1/8G - mit Filter Produktreferenz: 9PF18-4-F
--	---	---	--	--